

BASSOON FINGERING CHART

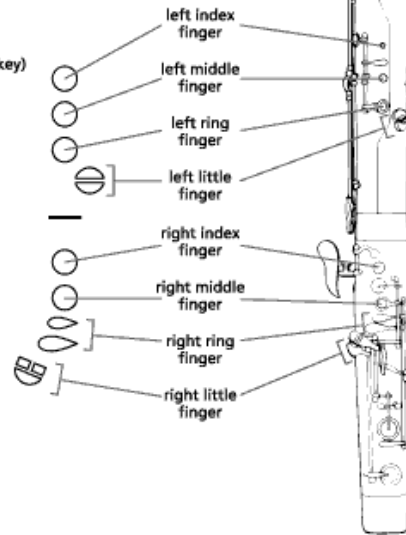
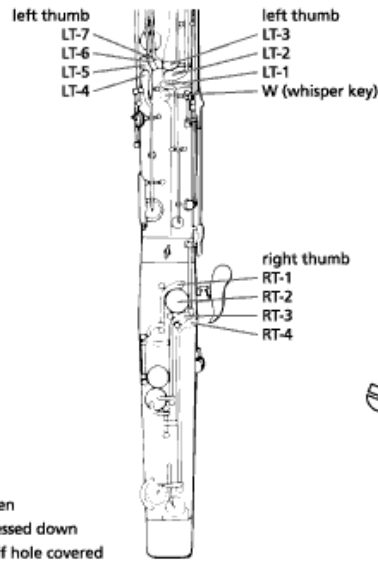

- = open
- = pressed down
- ◐ = half hole covered

Diagram showing fingering charts for various notes on the bassoon, organized into seven rows of musical staves. Each staff shows a note and its corresponding fingering diagram. The diagrams use symbols defined in the legend: open circles (○) for open keys, solid circles (●) for pressed down keys, and half-filled circles (◐) for half-hole covered keys.

Row 1: B^b, B, C, C[#], D^b, D, D[#], E^b

Row 2: E, F, F[#], G^b, G, G[#], A^b

Row 3: A, A[#], B^b, B, C, C[#], D^b

Row 4: D, D[#], E^b, E, F, F[#], G^b

Row 5: G, G[#], A^b, A, A[#], B^b, B, C

Row 6: C[#], D^b, D, D[#], E^b, E, F, F[#], G^b, G

Fingering diagrams include labels for left thumb (LT-1 to LT-7), right thumb (RT-1 to RT-4), and fingers (index, middle, ring, little). Some diagrams also include 'W' for the whisper key.

*On some bassoons, high F[#]/G^b can be played more in tune by adding the left hand 3rd (ring) finger to one of the standard fingerings.