

# JAZZ ENSEMBLE

2022-2023

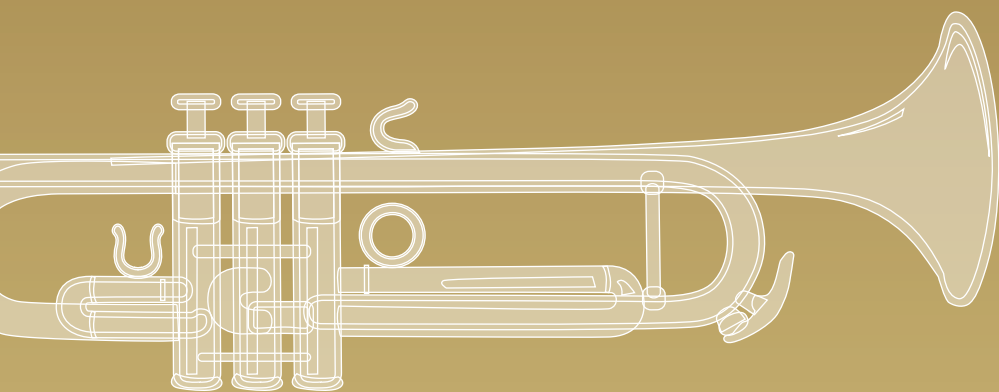

100 YEARS

CELEBRATING A CENTURY OF



Alfred Music



## JAZZ BEGINNINGS Grades ½–1

**Instrumentation:** 2 altos, 2 tenors, 2 trumpets, 2 trombones, piano, bass, drumset.

**Optional Parts:** 2 flutes, 2 clarinets, baritone horn TC / tenor sax, F horn, baritone saxophone, tuba, guitar, and vibraphone. Playable with reduced instrumentation.

**Instrument Ranges**

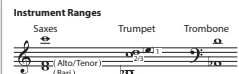



## FIRST YEAR CHARTS FOR JAZZ ENSEMBLE Grade 1

**Instrumentation:** 5 saxes, 3 trumpets, 3 trombones, 4 rhythm.

**Optional Parts:** flute, clarinet, F horn, and baritone horn TC / tenor sax, tuba, and vibraphone. Playable with reduced instrumentation.

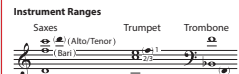
**Instrument Ranges**





## YOUNG JAZZ ENSEMBLE Grade 2

**Full Instrumentation:** 5 saxes, 4 trumpets, 4 trombones, 4 rhythm.

**Optional Parts:** flute, clarinet, F horn, 1/2 baritone horn TC / tenor sax, tuba, and vibraphone. Playable with reduced instrumentation.

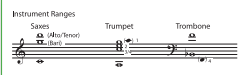
**Instrument Ranges**





## JAZZ BAND Grades 3–3½

**Full Instrumentation:** 5 saxes, 4 trumpets, 4 trombones, 4 rhythm.

**Optional Parts:** flute, F horn, 1/2/3 baritone horn TC / tenor sax, tuba, and vibraphone.

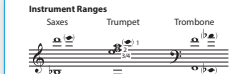
**Instrument Ranges**



## PREMIER JAZZ Grades 4–5

**Full Instrumentation:** 5 saxes, 4 trumpets, 4 trombones, 4 rhythm.

**Instrument Ranges**

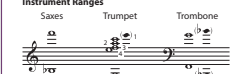

## PATRICK WILLIAMS Grade 6

**Full Instrumentation:** 5 saxes, 4 trumpets, 4 trombones, 4 rhythm. Additional optional parts vary.



## JAZZ VOCAL Grades 3–3½

**Full Instrumentation:** vocal solo, 5 saxes, 4 trumpets, 4 trombones, 4 rhythm.



## BELWIN JAZZ LEGENDS Grade 6

**Full Instrumentation:** 5 saxes, 8 brass, 4 rhythm (instrumentation varies).



## GORDON GOODWIN Grades 5–6

**Full Instrumentation:** 5 saxes, 4 trumpets, 4 trombones, 4 rhythm. Many charts include auxiliary percussion.



## GORDON GOODWIN Little Phat Band Grade 6

**Full Instrumentation:** 1 trumpet, 1 tenor sax, 1 trombone, 4 rhythm. Many charts include auxiliary percussion.

## Table of Contents

New Performance Music .....	4–8
Play-Alongs .....	9–10
Bob Mintzer & The Articulate Jazz Musician .....	11
Advance Music .....	12
Jamey Aebersold .....	13
Supplemental & Instrument-Specific Studies .....	14–15

---

### Dear Jazz Educator,

2022 JAZZ is here!

We have outstanding new performance music this year, so please check out the variety of styles, difficulty levels, and tempos which are clearly indicated in this catalog. You can listen to all the full-length demo recordings and examine the scores as well online at [alfred.com/NewJazz](https://alfred.com/NewJazz).

In this catalog, we showcase the terrific Advance Music library, jazz play-alongs, Jamey Aebersold play-alongs, the music of Gordon Goodwin, Bob Mintzer jazz etudes, The Articulate Jazz Musician, a variety of superb rhythm section material, and an assortment of technique studies. You can check out all our resources online at [alfred.com](https://alfred.com).

Here's a milestone: Alfred Music celebrates 100 years in 2022! Everyone at Alfred shares your love for music and I personally share your passion for jazz. We know that quality music along with supporting supplemental materials is a catalyst for great jazz education.

Have a great year, and most importantly—have fun playing jazz!



*Pete BarenBregge*

**Pete BarenBregge**

Instrumental Jazz Editor

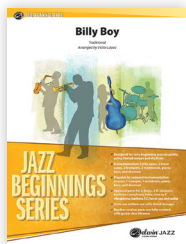

## Jazz Beginnings Series

### Night and Day

Words and music by Cole Porter / arr. Victor López

This is classic Cole Porter at a very accessible level.

There are no individual solos, but the chart features easy ranges and a bossa-nova groove played around 120 BPM.

Optional flutes, clarinets, vibes, and more. (2:33)

(00-49610) ..... \$40.00

### Billy Boy

Traditional / arr. Victor López

A modern treatment of the well-known folk song, this chart contains some modern harmony and easy syncopation featuring a rock groove with optional parts. (2:15)

(00-49200) Available in SmartMusic ..... \$40.00

### Drama for Your Mama

By Victor López

López has created a fun rock chart for the jazz beginner with easy rhythms, ranges, and a solo section for all the winds.

The written-out solo can be performed by individuals or any combination. Easy to put together and very effective—it practically plays itself! (3:42)

(00-26853) Available in SmartMusic ..... \$40.00



## First Year Charts for Jazz Ensemble

### These Toys Swing

(March of the Toys)

By Victor Herbert / arr. Michael Story

This perfect holiday chart features trumpet 1 range to written E top space, a written-out tenor sax 1 solo, and well-notated rhythm section parts played at 144 BPM! (2:19)

(00-49611) ..... \$42.00

### Naptown Blues

By John L. (Wes) Montgomery / arr. Terry White

Terry White's chart is an accessible straight-ahead swinger played around 150 BPM, with a nice sax soli, written-out solos for alto 1, tenor 1, trumpet 1, and trombone 1. Check the hot shout chorus! (3:16)

(00-49612) ..... \$40.00

### Curacao Blue

By Zachary Smith

This Latin groove chart features an easy bossa rhythmic pattern. The tempo is around 134 BPM, trumpet 1 range to written E top space, a written tenor solo, and clear articulation with complete rhythm section notation. (3:10)

(00-49613) ..... \$40.00

### My Groove, Your Move

Words and music by Hank Mobley / arr. Terry White

This moderate swing played at 132 BPM features a catchy melody, a few sax solis, and written-out solos for trumpet 1 and trombone 1. The lead trumpet range is to written E top space. (3:00)

(00-49201) Available in SmartMusic ..... \$42.00

### Moondance

Words and music by Van Morrison / arr. Mike Story

The favorite classic rock shuffle is played around 134 BPM with written-out solos for alto, tenor, trumpet 1, and trombone 1. No worries for trumpet 1 range which is to written D fourth line. (3:15)

(00-49202) Available in SmartMusic ..... \$42.00

### Uptown Throwdown

By Zachary Smith

This is a very cool shuffle-swing groove chart played around 140 BPM with a stop-time interlude, a big shout chorus, and an optional vocal shout-out too! Optional parts for flute, clarinet, vibes, and more. (4:05)

(00-49203) ..... \$42.00

GRADE  
1

GRADE  
1

GRADE  
1/2

GRADE  
1

GRADE  
1/2

GRADE  
1

GRADE  
1

GRADE  
1

GRADE  
1

## SCORE & SOUND

Subscribe and see the score while the recording plays. Your students can use the professional recordings as a reference for expression and musicianship. Our professional jazz recordings include awesome solos that serve as great examples for students.

[alfred.com/JazzScore](http://alfred.com/JazzScore)



### Alligator Boogaloo

By Lou Donaldson / arr. Terry White

This simple blues chart has a funky rock, aka, a boogaloo groove played around 136 BPM. It has a great melody introduced by alto and trumpet. Written solos provided for alto, tenor, trumpet, and trombone; optional parts include vibes. (3:25)

(00-46147) ..... \$42.00

GRADE  
**1**

### Sleigh Ride

By Leroy Anderson / arr. Mike Story

Scored for young band accessibility, this classic tune includes written melodic solos for alto and tenor sax, easy brass ranges, simple rhythms, and all the optional parts to include flute, clarinet, and vibraphone. (2:13)

(00-45063) Available in SmartMusic ..... \$44.00

GRADE  
**1**

### No Harm / No Fowl

By Kris Berg

This year's annual chicken chart has a very accessible rock groove played around 146 BPM, written-out solo opportunities for all saxes and brass, and the lead trumpet range is to written G on top of the staff. (4:30)

(00-49616) Available in SmartMusic ..... \$48.00

GRADE  
**2½**

#### IN THE MOOD FOR CHICKEN?

Check out the playlist at [alfred.com/PlayFunkyChicken](http://alfred.com/PlayFunkyChicken).



#### LOOKING FOR MORE HOLIDAY JAZZ CHARTS?

Check out the playlist at [alfred.com/PlayJazzHoliday](http://alfred.com/PlayJazzHoliday).

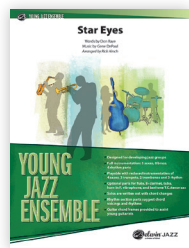

## Young Jazz Ensemble

### Compared to What

Words and music by Eugene McDaniels / arr. Mike Kamuf

This straight-eighth groove chart has a distinctive Les McCann flavor. Played around 148 BPM, written solos are provided for tenor 1 and trumpet 2. Unison sax lead lines, some written drum fills, and a sweet shout chorus make this a fine chart! (4:01)

(00-49614) Available in SmartMusic ..... \$48.00

GRADE  
**2½**

### Star Eyes

Words by Don Raye, music by Gene DePaul / arr. Rick Hirsch

Rick Hirsch's finely crafted chart has a straight-eighth groove played around 148 BPM. Eight-bar solos are written out for alto 1, tenor 1, trumpet 1, and trombone 1, and the lead trumpet range is to written A above the staff. (4:20)

(00-49615) ..... \$48.00

GRADE  
**2½**

### Poinciana

Words by Buddy Bernier, music by Nat Simon / arr. Mike Dana

This jazz standard is treated with a light and funky groove played around 92 BPM. Written-out solos are provided for trumpet 1 (optional flugelhorn) and alto 1 with some very nice ensemble sections. (4:22)

(00-49617) ..... \$48.00

GRADE  
**2½**

### Stompin' at the Savoy

By Benny Goodman, Chick Webb, and Edgar Sampson / arr. Mike Kamuf

This great jazz standard is played around 156 BPM and features section solis, interludes, and a kickin' shout chorus—it's all here! This swinger is superbly arranged to feature five soloists; trombone 1, trumpet 2, tenor 1, alto 1, and drumset. (4:20)

(00-49204) FREE in SmartMusic ..... \$48.00

GRADE  
**2½**

### Son of the Chicken

By Kris Berg

This funky original is accessible for younger bands, and features a chorale intro and written solos for trumpet 1 and tenor 1. The lead trumpet range is to written G on top of the staff. (3:30)

(00-49205) Available in SmartMusic ..... \$48.00

GRADE  
**2**

## PLAYLIST

You and your students can stream our new charts at any time, on any device. Great for listening and familiarizing themselves with the solos or difficult passages!

[alfred.com/Jazz22Play](http://alfred.com/Jazz22Play)



### 'Round Midnight

GRADE  
2½

Words by Bernie Hanighen, music by Cootie Williams and Thelonious Monk / arr. Rick Hirsch

Typically a ballad, this treatment is a straight-eighth feel with smooth cascading lines, a few sax solis, beautiful harmonies, and optional parts. Played around 140 BPM, the lead trumpet range is to written G on top of the staff. (4:25)

(00-49206) Available in SmartMusic..... \$48.00

### Recorda Me

GRADE  
2½

(Remember Me)

By Joe Henderson / arr. Mike Kamuf

One of the best jazz standards has been arranged in a Latin groove played at 156 BPM. The melody is handled by tenor, trumpet, and guitar with written solos provided for tenor and trumpet. Lead trumpet range is to written G on top of the staff. (4:48)

(00-47513) Available in SmartMusic..... \$50.00

### Mary, Did You Know?

GRADE  
2½

Words and music by Mark Lowry and Buddy Greene / arr. Rich Sigler

This beautiful holiday rock ballad is played around 98 BPM. The opening melody on this tender ballad is written featuring your 1st tenor sax player. Lead trumpet range is to written F on the top line. Sweet chart! (3:26)

(00-47029)..... \$50.00

### It Don't Mean a Thing

GRADE  
2½

(If It Ain't Got That Swing)

Music by Duke Ellington, words by Irving Mills / arr. Ralph Ford

This chart begins as a Latin then alternates with a clever swing feel. The tempo is bright at around 190–200 BPM. With written-out solos for trumpet and tenor sax, a few piano montunas, and a big shout chorus. (3:20)

(00-46157)..... \$48.00

### I'll Be Home for Christmas

GRADE  
2

Words by Kim Gannon, music by Walter Kent / arr. Peter Blair

Easy to rehearse, this holiday chart will sound great! Start with a classic played around 92 BPM in a light rock groove, add written melody solos, and easy ranges—this is a win-win for everyone! (2:50)

(00-46154)..... \$48.00

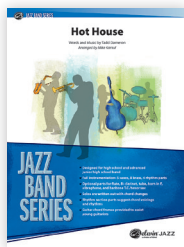

## Jazz Band Series

### Hot House

GRADE  
3½

Words and music by Tadd Dameron / arr. Mike Kamuf

Played at 154 BPM, the distinctive melody is handled by alto 1 and trumpet 2 with written solos for both. This first-class chart features a serious sax soli and a powerful shout chorus. (4:34)

(00-49618)..... \$52.00

### My Foolish Heart

GRADE  
3½

Words by Ned Washington, music by Victor Young / arr. Alan Baylock

This classic chart is a superb ballad featuring trumpet 2 played around 70 BPM. It features a double-time section with a suggested written solo, lush rubato sections, and the lead trumpet range is to written A above the staff. (5:04)

(00-49619) Available in SmartMusic..... \$52.00

### Change Is Good

GRADE  
3½

By Gordon Goodwin

This Latin straight-eighth groove is mellow and refreshing, played at 125 BPM. The lead trumpet range is to written G-sharp on the staff, suggested written solos provided for flexibility for C, B-flat, E-flat, and bass clef instruments. (5:27)

(00-49620)..... \$52.00

### Brincando com Fogo

GRADE  
3½

(Dancing with Fire)

By Drew Zaremba

This energetic and fiery baião Latin chart is played at half note = 100 BPM. The lead trumpet range is to written G on top of the staff and suggested solos are written for tenor 1 and trumpet 2. (6:16)

(00-49621)..... \$52.00

## ALFRED & SMARTMUSIC BLOGS

With articles by Mike Kamuf, Jim Snidero, Pete BarenBregge, and more, you're sure to find tips and tricks for teaching aspects of jazz to your ensemble.

[alfred.com/JazzBlog](http://alfred.com/JazzBlog)  
[smartmusic.com/JazzBlog](http://smartmusic.com/JazzBlog)



## PRINT ON DEMAND

Access thousands of full ensemble pieces and individual parts instantly on TotalSheetMusic.com. Print or view your digital sheet music at home or your local dealer.

[TotalSheetMusic.com/Jazz](http://TotalSheetMusic.com/Jazz)



**My Man Sam**

For Sammy Nestico

By Gordon Goodwin

A tribute to the late Sammy Nestico, the superb writing provides sweet sax solis, dynamic contrasts, and a wonderful shout chorus. The medium swing tempo is 134 BPM and the lead trumpet range is to written B above the staff. (4:45)

(00-49209) Available in SmartMusic..... \$52.00

GRADE  
**3½**

**What Is This Thing Called Love?**

From *Wake Up and Dream*

Words and music by Cole Porter / arr. Alan Baylock

This hot swinger is full of energy and played in double time around 110 BPM that alternates with a samba groove and features a tenor 1 solo. This is your opener or closer for every performance! (4:15)

(00-49210) Available in SmartMusic..... \$52.00

GRADE  
**3½**

**Alone Together**

Lyrics by Howard Dietz, music by Arthur Schwartz / arr. Mike Kamuf

This jazz standard is played around 124 BPM with solo space for tenor 1 with a sample solo, and a trombone soli. The lead trumpet range is to written B above the staff. A first-class chart! (5:30)

(00-49211) ..... \$52.00

GRADE  
**3½**

**Lush Life**

By Billy Strayhorn / arr. Mike Kamuf

Played at around 88 BPM moving into a double-time bossa section leading into the finale, you'll enjoy every measure of this excellent chart. Only written melody solos for alto and trumpet, no improv, and all the usual optional parts plus vibes. (3:40)

(00-46161) Available in SmartMusic..... \$52.00

GRADE  
**3½**

**Things Ain't What They Used to Be**

Music by Mercer Ellington / arr. Alan Baylock

This terrific shuffle swings at 120 BPM and features a classic melody with written solos available for alto, trumpet, trombone, and tenor sax. A powerful Baylock-style shout chorus is a hit, and the lead trumpet range is to written G on top of the staff. (6:14)

(00-43708)..... \$52.00

GRADE  
**3**

**Work Song**

By Nat Adderley / arr. Erik Morales

A great jazz standard, this swing chart plays well at 176 BPM. Features include a lead trumpet range to written A above the staff, written alto and trumpet solos, a great shout chorus, and cool development section. (4:49)

(00-43689)..... \$54.00

GRADE  
**3**

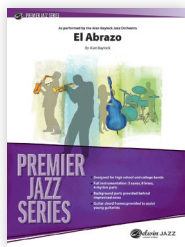

**Premier Jazz Series**

**El Abrazo**

By Alan Baylock

GRADE  
**4**

The ballad beginning and ending is truly beautiful. The chart moves to a samba around 110 BPM for the half note. Lead trumpet range is to written high C and there is a tenor solo with chord changes. (7:35)

(00-45080) Available in SmartMusic..... \$60.00

**Cold Duck Time**

As Recorded by Alan Baylock Jazz Orchestra

By Eddie Harris / arr. Alan Baylock

GRADE  
**4**

This exciting chart has a straight-eighth groove at 120 BPM with a written tenor solo. The lead trumpet range is to written C above the staff. Includes optional flute and vibes parts too. Outstanding! (6:34)

(00-43701) Available in SmartMusic ..... \$60.00

smartmusic.

Practice Tools for  
Beginning Jazz Students

Learning to swing is easier with SmartMusic. Automatic rhythmic assessments can be adjusted from light bebop swing feel to the dotted eighth swing of heavy shuffle.

1st 5b TENOR SAXOPHONE

By Eddie Harris  
Arranged by Erik Morales



Many Belwin jazz charts include two versions in SmartMusic: A full performance version that includes recorded solos and a solo practice version without the soloist, allowing your students space to try out their own solos or to emulate the professional musician on the recording.

Learn more at [smartmusic.com](http://smartmusic.com)

**READY TO BUY?**

Visit [alfred.com/NewJazz](http://alfred.com/NewJazz) or your local music retailer and order today.

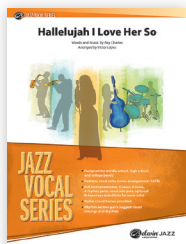

## Jazz Vocal Series

### Hallelujah I Love Her So

GRADE 3

Words and music by Ray Charles / arr. Victor López

This shuffle swing vocal chart is an upbeat song with lyrics provided to accommodate female or male vocalists. The tempo is around 142 BPM, with a few stop time sections and no horn solos. The vocal range is from B-flat below middle C to third space B-flat. (3:05)

(00-46169) Available in SmartMusic ..... \$54.00

### Cry Me a River

GRADE 3

Words and music by Arthur Hamilton / arr. Victor López

This gorgeous vocal ballad with big band is played around 74 BPM. The vocal range is G below middle C to third space C. Includes optional lead parts for B-flat, E-flat, and bass clef instruments. (3:21)

(00-41160) ..... \$54.00



## Gordon Goodwin Series

### (The) Very Best of Times

GRADE 5

By Gordon Goodwin

This very playable swing chart at 140 BPM has solo space for alto, tenor, trumpet, trombone, and/or piano. The lead trumpet range is to written high E. A tasty Basie-style chart that is accessible to a good high school band. (8:07)

(00-36071) ..... \$65.00



## Gordon Goodwin Little Phat Band Series

### Cot in the Act

GRADE 5

As Performed by Gordon Goodwin's Little Phat Band  
By Gordon Goodwin

Funky with a hip piano intro, this chart includes solo space for all. For tenor, trumpet, trombone, piano, bass, guitar, and drums. (2:16)

(00-41148) Available in SmartMusic ..... \$48.00



## Jazz Legend Series

### Day Dream

GRADE 5

By Duke Ellington and Billy Strayhorn / ed. and transcr. Jeff Lindberg

A beautiful alto saxophone ballad, the tempo is around 72 BPM and the instrumentation is 5 saxes, 1 trumpet, 3 trombones, piano, bass, and drums. Edited and adapted in exacting detail.

(00-45085) ..... \$70.00

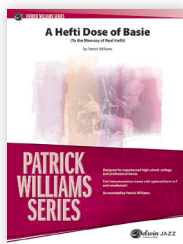

## Patrick Williams Series

### A Hefti Dose of Basie

GRADE 4

To the Memory of Neal Hefti  
By Patrick Williams

As performed on Patrick William's CD *Home Suite Home*, this chart is a marvel of taste and restraint. The tempo is slow at around 74 BPM. This outstanding ballad has a trumpet 2 solo with chord changes. Brass range is not an issue, the challenge is the slow tempo. (4:17)

(00-45087) ..... \$80.00

LOOKING FOR MORE PHAT BAND CHARTS?

Check out the playlist at [alfred.com/PlayPhatCharts](http://alfred.com/PlayPhatCharts).







## Learning Improvisation Through Practice

Alfred jazz play-alongs go well beyond others by providing a sample written-out solo for students to listen, play, and practice. The demo and play-along tracks allow the musician to practice with or without their part remove from the mix, as well as to slow down the track to better practice difficult parts. Specific improvisation tips and suggestions are included.

### Two formats for each title:

C, B-flat, E-flat & Bass Clef Instruments Book & CD .....	\$17.95–\$25.99
Rhythm Section (Piano, Bass & Drumset) Book & CD .....	\$21.99–\$24.99

### Easy

#### Alfred Jazz Easy Play-Along Series, Vol. 1: Easy Standards

Titles: Ain't Misbehavin' • Blue Train • Impressions • Killer Joe • Jive Samba • Little Sunflower • My Little Suede Shoes • Perdido • Work Song.

#### Alfred Jazz Easy Play-Along Series, Vol. 2: Easy Standards

Titles: After You've Gone • Blues March • Lazy Bird • Lester Leaps In • Mr. PC • Road Song • Scrapple from the Apple • St. James Infirmary • Summertime.

#### Alfred Jazz Easy Play-Along Series, Vol. 3: Easy Latin Standards

Titles: Gentle Rain • Listen Here • Manha de Carnival • Night and Day • Poinciana • Recorda Me • The Shadow of Your Smile • Softly, as in a Morning Sunrise • Star Eyes.

### Medium-Easy

#### Alfred Jazz Play-Along Series, Vol. 1: Strayhorn & More

Titles: Caravan • Chelsea Bridge • Freddie Freeloader • Isfahan • Johnny Come Lately • Prelude to a Kiss • Raincheck • Take the "A" Train • Upper Manhattan Medical Group.

#### Alfred Jazz Play-Along Series, Vol. 2: Swingin' Now

Titles: Stella by Starlight • On Green Dolphin Street • Have You Met Miss Jones? • Bye Bye Blackbird • What Is This Thing Called Love? • Days of Wine and Roses • I Got Rhythm • Stompin' at the Savoy • Just Friends.

#### Alfred Jazz Play-Along Series, Vol. 3: Brubeck & More

Titles: Alone Together • Good Bait • How High the Moon • In Your Own Sweet Way • Invitation • It's a Raggy Waltz • Old Devil Moon • Robbin's Nest • Unit 7.

### Medium-Advanced

#### Alfred Jazz Play-Along Series, Vol. 4: The Music of Gordon Goodwin

Titles: Count Bubba's Revenge • High Maintenance • Howdiz Songo? • Jazz Police • Maynard & Waynard • Race to the Bridge • Rippin' 'n Runnin' • That's How We Roll • The Very Best of Times.

#### Alfred Jazz Play-Along Series, Vol. 5: Freddie Hubbard & More

Titles: Crisis • Gibraltar • Hot House • Little B's Poem • Night and Day • Red Clay • 'Round Midnight • Sky Dive • Up Jumped Spring.

# GORDON GOODWIN'S

## BIG Phat BAND Play-Along Series

Learn volumes of information about advanced style, phrasing, tone, dynamics, technique, articulation, playing in time, Latin grooves, and a variety of swing styles. Performance tips and suggestions from the Big Phat Band's lead players and Gordon himself are included in each book.



### Volume 1 Available in SmartMusic!

Titles: Swingin' for the Fences • La Almeja Pequeña • Hunting Wabbits • Whodunnit • Count Bubbas Revenge • Get in Line • Horn of Puente • The Jazz Police • High Maintenance • Cut 'n Run.

Alto Saxophone Book & Online Audio/Software (00-25244) .....	\$24.95
Tenor Saxophone Book & Online Audio/Software (00-25247) .....	\$24.95
Trumpet Book & Online Audio/Software (00-25250) .....	\$24.99
Trombone Book & Online Audio/Software (00-25253) .....	\$24.95
Drums Book & Online Audio/Software (00-25256) .....	\$24.95

### Volume 2

Titles: That's How We Roll • Rippin' 'n' Runnin' • Why We Can't Have Nice Things • Garaje Gato • It's Not Polite to Point • Gaining on You • Howdiz Song? • Does This Chart Make Me Look Phat? • Race to the Bridge.

Alto Saxophone Book & CD (00-42575) .....	\$24.99
Tenor Saxophone Book & CD (00-42578) .....	\$24.99
Trumpet Book & Online Audio/Software, including <i>Playing Lead Trumpet</i> (00-43709) .....	\$29.99
Trombone Book & CD (00-42584) .....	\$24.99
Drums Book & CD (00-42587) .....	\$24.99

## Practice Online with the Big Phat Band

Your students can play along with the Big Phat Band recordings, loop and/or slow down to master difficult sections, and adjust how much they want to hear their own part and the accompaniment.

available in  
**smartmusic.**

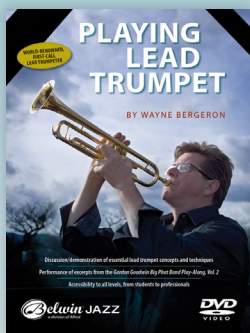

## Play the Phat Band Charts with Wayne Bergeron

### Playing Lead Trumpet

By Wayne Bergeron

Wayne Bergeron discusses and demonstrates the essential aspects of lead trumpet playing for all levels, from students to professionals using charts from the *Gordon Goodwin Big Phat Band Play-Along Series: Trumpet, Volume 2*.

DVD (00-43718) .....	\$19.99
Trumpet Book & Online Video/Audio/Software (Playing Lead Trumpet) .....	\$29.99



## Learn to Improv on the Changes with Bob Mintzer Etudes

World-renowned jazz composer, arranger, saxophonist, bandleader, and educator Bob Mintzer has written out etude solos in several styles so your students can familiarize themselves with the changes and harmonic settings. Performance notes and tips for each etude assist in interpretation and improvisation, and the play-along CD, featuring a stellar rhythm section, provides plenty of opportunity to practice.

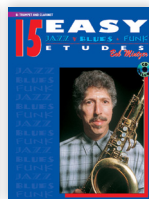
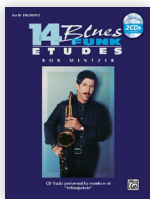
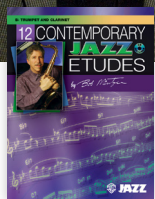

## Create a Cohesive Sound for Your Ensemble

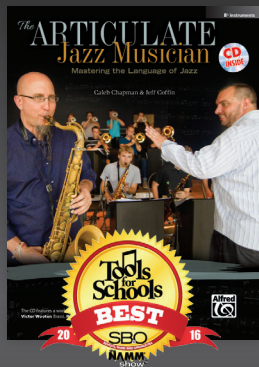

"As educators, we often feel like jazz instruction should start with improvisation, but that's really putting the cart before the horse. In the English language we teach vocabulary words to young students before we teach them to speak and write in complete sentences. In the same way, *The Articulate Jazz Musician* gives students the critical vocabulary they need to be able to create stylistically correct jazz phrases in both written music and improvising."



### Caleb Chapman

Award-Winning Jazz Educator  
 Founder & Chairman, Caleb Chapman's Soundhouse



### Jeff Coffin

Musician, Educator, Composer, and Author  
 Multi GRAMMY® Award-Winning Saxophonist  
 (Dave Matthews Band)

available in  
**smartmusic.**

Learn more at [alfred.com/AJM](http://alfred.com/AJM).

**READY TO BUY?**

Visit [alfred.com/NewJazz](http://alfred.com/NewJazz) or your local music retailer and order today.



# Jim Snidero's Jazz Conception Series



Used by students, private teachers, high schools, colleges, and even jazz pros, this innovative series is the best-selling, most popular series in the world.

Here's why:

- Authentic-sounding etudes based on chord progressions to standards, jazz tunes, and blues, in the styles of jazz greats such as Charlie Parker, Miles Davis, Sonny Rollins, Herbie Hancock, and more.
- The included play-along recordings feature phenomenal musicians including Slide Hampton, Frank Wess, Kenny Washington, Jim Snidero, and others—expertly demonstrating how to phrase and swing.
- Available for almost every instrument, in three levels of difficulty to meet students where they're at: *Easy*, *Intermediate*, and the original *Jazz Conception*.

## Check Out Jim Snidero's Essence Books!

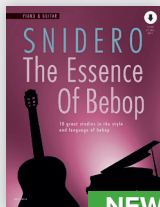
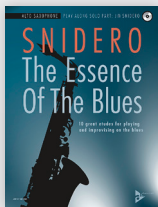

Available for flute, clarinet, tenor sax, alto sax, trumpet, and trombone.

Features 10 etudes in the styles of the greats such as Charlie Parker, B.B. King, John Coltrane, and more.

**NEW!** Piano/Guitar book for *Essence of Bebop!*

Best-Selling Jazz Resources from *Jamey Aebersold Jazz*® 

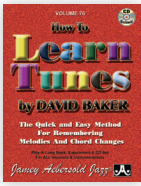

**Jamey Aebersold Jazz, Volume 76: How to Learn Tunes**

The Quick and Easy Method for Remembering Melodies and Chord Changes

By David Baker

This incredible work is a quick and easy method for learning and memorizing melodies and chord changes to any tune in any key! Listening / learning / play-along tracks take you through the most commonly used harmonic formulas.

Book & Online Audio (24-V76DS).....\$21.95

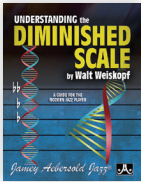

**Understanding the Diminished Scale**

A Guide for the Modern Jazz Player

By Walt Weiskopf

This book explains everything you need to know about the versatile diminished scale and how / where to use it in your solos. Includes 12 exercises, 6 common patterns, and 4 classic diminished licks over ii-V7-I tracks. 104 pages.

Book (24-UDS) .....\$19.95

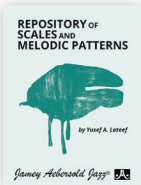

**Repository of Scales and Melodic Patterns**

By Yusuf A. Lateef

This legendary spiral-bound book, with a wealth of patterns, licks, and ideas, has been popular among jazz players for a long time. Page after page of material has been collected from around the world during Yusuf's vast touring.

Treble Clef Spiral-bound Book (24-YL) .....\$39.95

Bass Clef Instruments Book (24-YL-B).....\$39.95

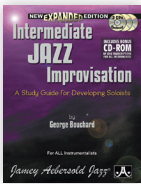

**Intermediate Jazz Improvisation**

A Study Guide for Developing Soloists

By George Bouchard

Features a 274 page book with downloadable play-along/demonstration tracks and 168 printable pages of transcribed solos transposed for C, B-flat, E-flat, and bass clef instruments! For those wishing to bridge the gap between playing scales, chords, and licks to playing realistic, flowing jazz lines.

Book & Online Audio (24-IJI).....\$38.95



**Jazz Piano Voicings for Non-Pianists**

For Individual or Group Study

By Mike Tracy

This book, designed by a horn player, addresses and explains the basics of authentic, hip sounding chord voicings in simple, non-pianistic language. Includes written voicings over many of the most popular Aebersold play-along tracks and downloadable play-along tracks.

Book (24-NON) .....\$27.95

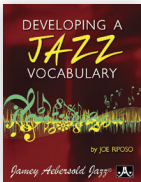

**Developing a Jazz Vocabulary**

By Joe Riposo

Linguistic references are essential because, just as we speak in words and phrases, so do we improvise jazz in musical phrases derived from notes. Choosing the right notes is essential to properly expressing ourselves and making a musical statement.

Book (24-DJV) .....\$12.95



**Playing Outside the Chord**

By David Kane

Featuring over 200 musical examples gleaned from classic solos, plus 15 extensive transcriptions of legendary performances, this book is skillfully designed to clue you in on the theoretical basis of "outside" play as practiced by these trail-blazing musicians.

Book (24-OTC).....\$32.00

## General Jazz Studies



### From Ragtime to Rock

An Introduction to 100 Years of American Popular Music

By Daniel Glass

DVD & CD-ROM (99-8304358452) ..... \$24.95

Google Classroom Version ..... \$29.99



### Meet the Great Jazz Legends

Short Sessions on the Lives, Times & Music of the Great Jazz Legends

By Ronald C. McCurdy

Book CD & Activity Sheets (00-32180) ..... \$39.99

Digital PDF Book & Audio ..... \$39.99



### Pentatonic Scales for Jazz Improvisation

By Ramon Ricker

Book (00-5B9) ..... \$16.95



### How to Play Bebop

By David Baker

Volume 1 (00-2746) ..... \$12.99

Volume 2 (00-2747) ..... \$12.99

Volume 3 (00-2748) ..... \$12.99



### Scales for Jazz Improvisation

By Dan Haerle

Book (00-5B7) ..... \$16.99

## Theory



### Alfred's Essentials of Jazz Theory

By Shelly Berg

Student Book & CDs ..... \$12.95

Teacher's Answer Key ..... \$39.99

Self-Study Book & 3 CDs ..... \$34.99

## Saxophone



### Jazz Conception: Alto and Baritone Saxophone

21 Solo Etudes for Jazz Phrasing, Interpretation, and Improvisation

By Jim Snidero

Book & Online Audio (01-ADV14720) ..... \$24.95

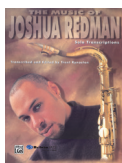

### The Music of Joshua Redman

Solo Transcriptions (Tenor Saxophone)  
Transcr. and ed. Trent Kynaston

Book (00-SB9701) ..... \$19.95

## Trumpet



### Jazz Trumpet Studies

By James Rae

Book (12-0571526489) ..... \$13.50

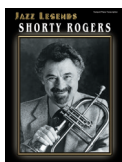

### Jazz Legends: Shorty Rogers

Trumpet/Piano Transcription

(00-IFM0059) ..... \$12.95

## Trombone

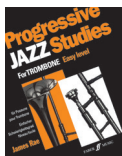

### Progressive Jazz Studies for Trombone

Book 1

By James Rae

Book 1 (12-0571515444) ..... \$14.95

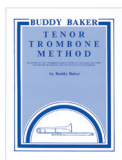

### Buddy Baker Tenor Trombone Method

By Buddy Baker

Book (00-SB153) ..... \$19.99

Voice



**Vocal Improvisation**

By Michele Weir

Book & CD (01-ADV14100) ..... \$44.95



**Musicianship for the Jazz Vocalist**

By Nancy Marano

Book & MP3 CD (01-ADV14108) ..... \$36.95



**Approaching the Standards for Jazz Vocalists**

By Dr. Willie L. Hill, Jr.

Book & CD (00-SBM00034CD) ..... \$17.95

Guitar



**Jazz Conception: Guitar**

21 Solo Etudes for Jazz Phrasing, Interpretation, and Improvisation  
By Jim Snidero

Book & MP3 CD (01-ADV14726) ..... \$24.95



**The Complete Jazz Guitar Method**

Complete Edition

By Jody Fisher

Book & Online Audio (00-34352) ..... \$29.99



**Playing Guitar in Jazz Band**

A Practical Guide for Students and Teachers

By David Sinclair

Guitar Book & CD (00-35431) ..... \$16.99

Drums



**Big Band Drumming Fill-osophy**

By Steve Fidyk and Dave Black

Book & MP3 CD (00-42309) ..... \$21.99

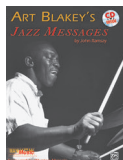

**Art Blakey's Jazz Messages**

Featuring Art Blakey, written by John Ramsay

Book & Online Audio (00-MMBK0059CD) ... \$25.99



**Jazz Drumset Etudes**

A Guide for Developing Solo Techniques and Melodic Vocabulary, Vol. 1

By Jake Reed

Book (00-42874) ..... \$12.99

Piano



**Big Phat Jazz Piano Solos**

10 Big Phat Band Classics Recomposed by Gordon Goodwin for Piano

By Gordon Goodwin

Book (00-46819) ..... \$9.50



**How to Play Jazz Piano**

A Fun and Simple Introduction to Playing Jazz Piano

By Pam Wedgwood

Book & Online Audio (12-0571539491) ..... \$19.95



**The Complete Jazz Keyboard Method**

By Noah Baerman

Beginning Keyboard/Piano Book & Online Video/Audio (00-45921) ..... \$19.99

Intermediate Keyboard/Piano Book & Online Video/Audio (00-45950) ..... \$19.99

Mastering Keyboard/Piano Book & Online Video/Audio (00-45951) ..... \$19.99

READY TO BUY?

Visit [alfred.com/NewJazz](http://alfred.com/NewJazz) or your local music retailer and order today.



**Alfred Music**  
LEARN • TEACH • PLAY



# *Celebrating a Century*

2022 is a special year for Alfred Music—it's our 100th anniversary of helping the world experience the joy of making music. Since 1922, Alfred Music has been a world leader in music education and has helped over 10 million individuals learn, teach, and play music through pedagogically sound products.

Thank you for the privilege of allowing us to be a part of your story.  
Here's to our next chapter together!

**alfred.com**

Sign up for the latest updates at [alfred.com/whatsnew](https://alfred.com/whatsnew)



Browse our new string & full orchestra releases at [alfred.com/NewJazz](https://alfred.com/NewJazz).

#107210

